

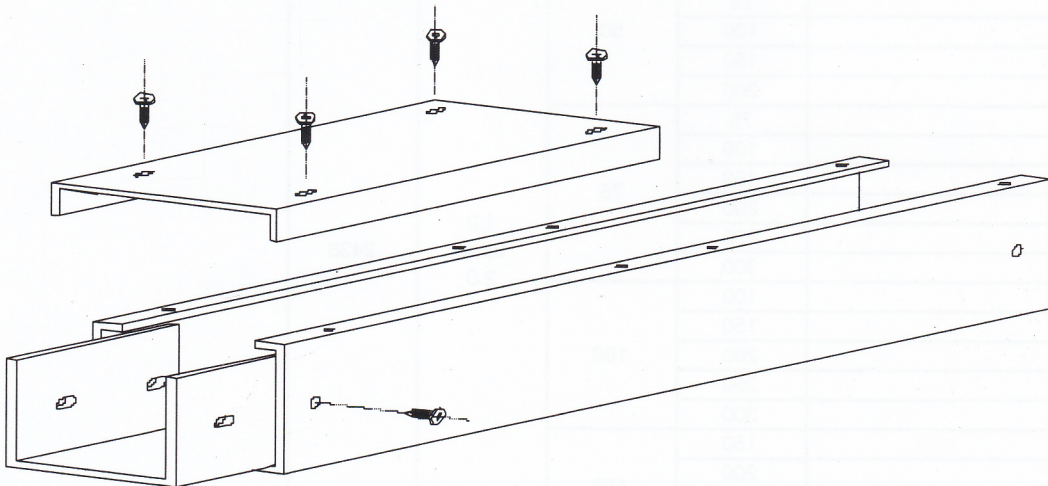

CABLE TRUNKING

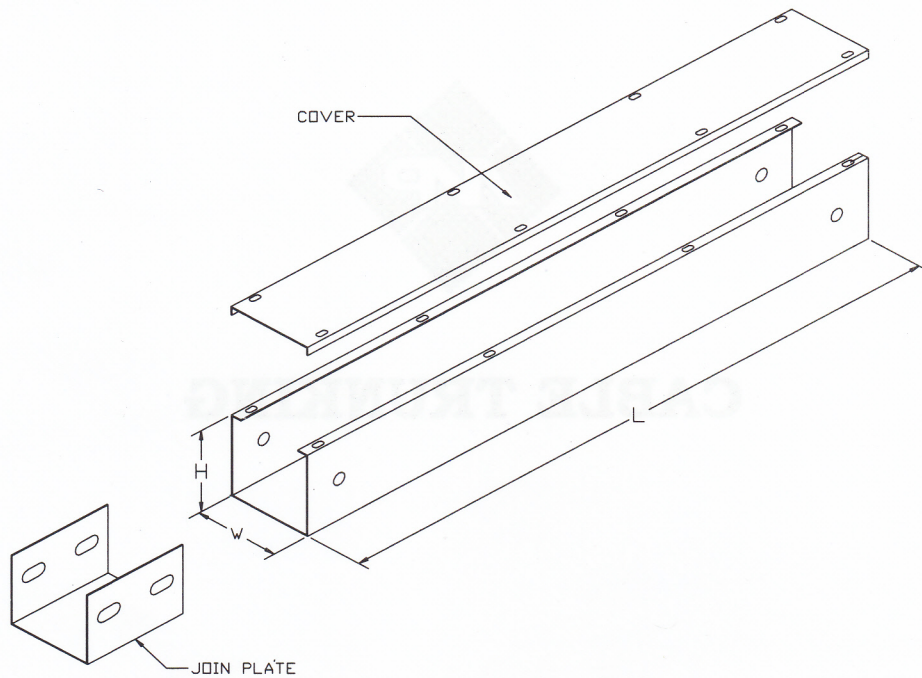

STRAIGHT CABLE TRUNKING



STANDARD DIMENSION				
PART NO.	W (mm)	H (mm)	T (mm)	L (mm)
MPSTG/50/50	50	50	1.0 up to 2.0	2438
MPSTG/50/75	75			
MPSTG/50/100	100			
MPSTG/50/150	150			
MPSTG/50/200	200			
MPSTG/75/75	75	75		
MPSTG/75/100	100			
MPSTG/75/150	150			
MPSTG/75/200	200			
MPSTG/75/250	250			
MPSTG/75/300	300	100		
MPSTG/100/100	100			
MPSTG/100/150	150			
MPSTG/100/200	200			
MPSTG/100/250	250			
MPSTG/100/300	300	150		
MPSTG/150/150	150			
MPSTG/150/200	200			
MPSTG/150/250	250			
MPSTG/150/300	300			

NOTE : Other sizes are available upon request

Standard Specifications:

- MATERIAL : Mild Steel / SS 304 / SS 316
- STD LENGTH : 2438 mm (± 6mm)
- FINISHING : HDG Accordance to ISO 1461 / BS 729 / ASTM A386 / Epoxy Powder Coating
- FASTENERS : HDG, EZP, SS 304 & SS 316

REMARKS:

MP : METAL PERFORATORS
SCT : STRAIGHT TRUNKING

EXAMPLE : MPSTG/100/150

METAL PERFORATORS
STRAIGHT TRUNKING
100H X 150W

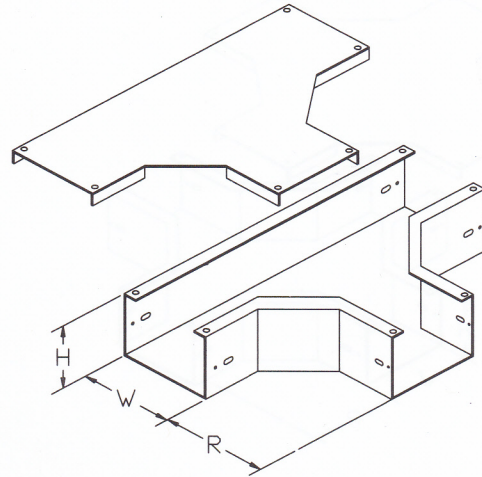
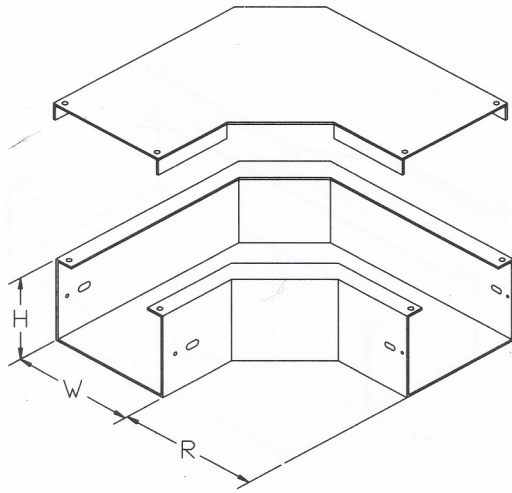

STANDARD DIMENSION				
PART NO	W 1(mm)	H (mm)	R (mm)	T (mm)
MPTGEL90/50/50	50	50	R200	1.0 up to 2.0
MPTGEL90/50/75	75			
MPTGEL90/50/100	100			
MPTGEL90/50/150	150			
MPTGEL90/50/200	200			
MPTGEL90/75/75	75	75		
MPTGEL90/75/100	100			
MPTGEL90/75/150	150			
MPTGEL90/75/200	200			
MPTGEL90/75/250	250			
MPTGEL90/75/300	300			
MPTGEL90/100/100	100	100		
MPTGEL90/100/150	150			
MPTGEL90/100/200	200			
MPTGEL90/100/250	250			
MPTGEL90/100/300	300			
MPTGEL90/150/150	150	150		
MPTGEL90/150/200	200			
MPTGEL90/150/250	250			
MPTGEL90/150/300	300			

STANDARD DIMENSION				
PART NO	W (mm)	H (mm)	R (mm)	T (mm)
MPTGHT/50/50	50	50	R200	1.0 up to 2.0
MPTGHT/50/75	75			
MPTGHT/50/100	100			
MPTGHT/50/150	150			
MPTGHT/50/200	200			
MPTGHT/75/75	50	75		
MPTGHT/75/100	75			
MPTGHT/75/150	100			
MPTGHT/75/200	150			
MPTGHT/75/250	200			
MPTGHT/75/300	300			
MPTGHT/100/100	100	100		
MPTGHT/100/150	150			
MPTGHT/100/200	200			
MPTGHT/100/250	250			
MPTGHT/100/300	300			
MPTGHT/150/150	150	150		
MPTGHT/150/200	200			
MPTGHT/150/250	250			
MPTGHT/150/300	300			

NOTE : Other sizes are available upon request

Standard Specifications:

1. MATERIAL : Mild Steel / SS 304 / SS 316
2. FINISHING : HDG Accordance to ISO 1461 / BS 729 / ASTM A386 / Epoxy Powder Coating
3. FASTERNERS : HDG, EZP, SS 304 & SS 316

REMARKS

MP : METAL PERFORATORS EL90 : HORIZONTAL ELBOW 90°
 TG : TRUNKING HT : HORIZONTAL TEE

EXAMPLE 1 : MPTGEL90/50/150
 METAL PERFORATORS
 TRUNKING - ELBOW 90°
 50H X 150W

EXAMPLE 2 : MPTGHT/50/150
 METAL PERFORATORS
 TRUNKING - HORIZONTAL TEE
 50H X 150W

TRUNKING - HORIZONTAL CROSS

TRUNKING - REDUCER LEFT/RIGHT

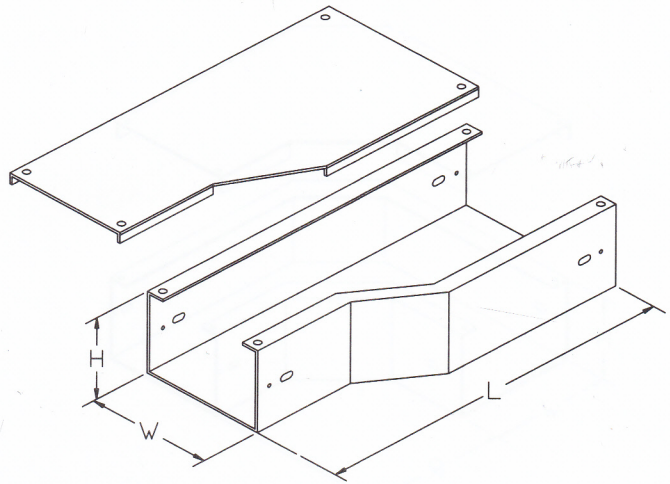
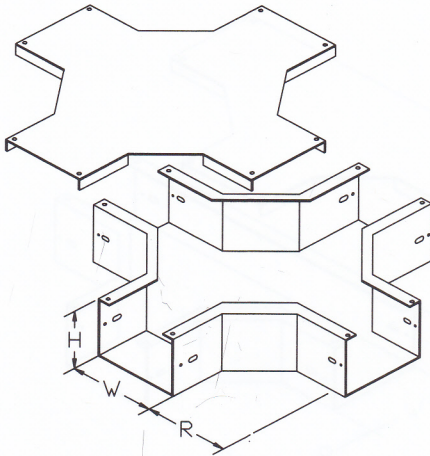

STANDARD DIMENSION

PART NO	W 1(mm)	H (mm)	R (mm)	T (mm)
MPTGHX/50/50	50	50	R200	1.0 up to 2.0
MPTGHX/50/75	75			
MPTGHX/50/100	100			
MPTGHX/50/150	150			
MPTGHX/50/200	200			
MPTGHX/75/75	75	75		
MPTGHX/75/100	100			
MPTGHX/75/150	150			
MPTGHX/75/200	200			
MPTGHX/75/250	250			
MPTGHX/75/300	300	100		
MPTGHX/100/100	100			
MPTGHX/100/150	150			
MPTGHX/100/200	200			
MPTGHX/100/250	250			
MPTGHX/100/300	300	150		
MPTGHX/150/150	150			
MPTGHX/150/200	200			
MPTGHX/150/250	250			
MPTGHX/150/300	300			

STANDARD DIMENSION

PART NO	W (mm)	H (mm)	L (mm)	T (mm)
MPTGRR/L/50/75-50	75-50	50	450	1.0 up to 2.0
MPTGRR/L/50/100-75	100-75			
MPTGRR/L/50/150-100	150-100			
MPTGRR/L/50/200-150	200-150			
MPTGRR/L/75/100-75	100-75			
MPTGRR/L/75/150-100	150-100			
MPTGRR/L/75/200-150	200-150			
MPTGRR/L/75/250-200	250-200			
MPTGRR/L/75/300-250	300-250			
MPTGRR/L/100/150-100	150-100	100		
MPTGRR/L/100/200-150	200-150			
MPTGRR/L/100/250-200	250-200			
MPTGRR/L/100/300-250	300-250			
MPTGRR/L/150/200-150	200-150			
MPTGRR/L/150/250-200	250-200			
MPTGRR/L/150/300-250	300-250			

NOTE : Other sizes are available upon request

Standard Specifications:

1. MATERIAL : Mild Steel / SS 304 / SS 316
2. FINISHING : HDG Accordance to ISO 1461 / BS 729 / ASTM A386 / Epoxy Powder Coating
3. FASTENERS : HDG, EZP, SS 304 & SS 316

REMARKS:

MP : METAL PERFORATORS HX : HORIZONTAL CROSS
 TG : TRUNKING RL : REDUCER LEFT RR : REDUCER RIGHT

EXAMPLE 1 : MPTGHX/50/150
 METAL PERFORATORS
 TRUNKING - HORIZONTAL CROSS
 50H X 150W

EXAMPLE 2 : MPTGRL/50/150-100
 METAL PERFORATORS
 TRUNKING - REDUCER LEFT
 50H X 150W-100W

TRUNKING - OUTSIDE RISER 90°

TRUNKING - INSIDE RISER 90°

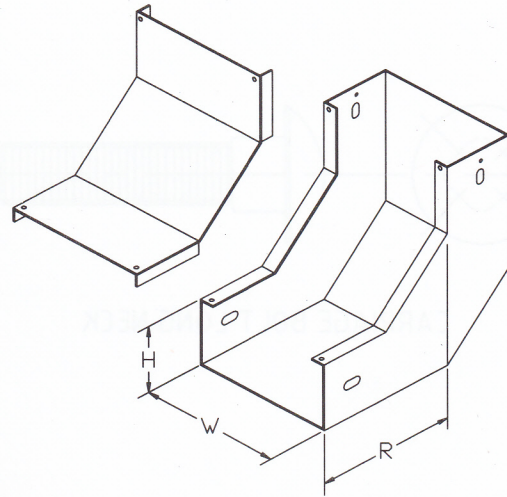
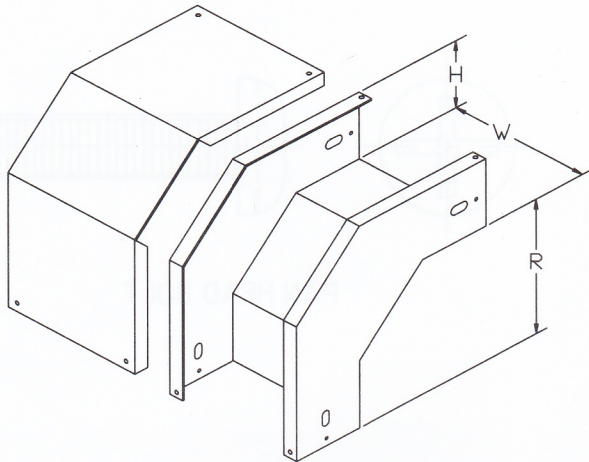

STANDARD DIMENSION				
PART NO	W 1(mm)	H (mm)	R (mm)	T (mm)
MPTGOR90/50/50	50	50	R200	1.0 to 2.0
MPTGOR90/50/75	75			
MPTGOR90/50/100	100			
MPTGOR90/50/150	150			
MPTGOR90/50/200	200			
MPTGOR90/75/75	75			
MPTGOR90/75/100	100			
MPTGOR90/75/150	150			
MPTGOR90/75/200	200			
MPTGOR90/75/250	250			
MPTGOR90/75/300	300			
MPTGOR90/100/100	100	100		
MPTGOR90/100/150	150			
MPTGOR90/100/200	200			
MPTGOR90/100/250	250			
MPTGOR90/100/300	300			
MPTGOR90/150/150	150			
MPTGOR90/150/200	200			
MPTGOR90/150/250	250			
MPTGOR90/150/300	300			

STANDARD DIMENSION				
PART NO	W 1(mm)	H (mm)	R (mm)	T (mm)
MPTGIR90/50/50	50	50	R200	1.0 to 2.0
MPTGIR90/50/75	75			
MPTGIR90/50/100	100			
MPTGIR90/50/150	150			
MPTGIR90/50/200	200			
MPTGIR90/75/75	75			
MPTGIR90/75/100	100			
MPTGIR90/75/150	150			
MPTGIR90/75/200	200			
MPTGIR90/75/250	250			
MPTGIR90/75/300	300			
MPTGIR90/100/100	100	100		
MPTGIR90/100/150	150			
MPTGIR90/100/200	200			
MPTGIR90/100/250	250			
MPTGIR90/100/300	300			
MPTGIR90/150/150	150			
MPTGIR90/150/200	200			
MPTGIR90/150/250	250			
MPTGIR90/150/300	300			

NOTE : Other sizes are available upon request

Standard Specifications:

- 1. MATERIAL : Mild Steel / SS 304 / SS 316
- 2. FINISHING : HDG Accordance to ISO 1461 / BS 729 / ASTM A386 / Epoxy Powder Coating
- 3. FASTERNERS : HDG, EZP, SS 304 & SS 316

REMARKS:

MP : METAL PERFORATORS IR90 : INSIDE RISER 90°
 TG : TRUNKING OR90 : OUTSIDE RISER 90°

EXAMPLE 1 : MPTGOR90/50/150
 METAL PERFORATORS
 TRUNKING - OUTSIDE RISER 90°
 50H X 150W

EXAMPLE 2 : MPTGIR90/50/150
 METAL PERFORATORS
 TRUNKING - INSIDE RISER 90°
 50H X 150W

BOLTS AND NUTS

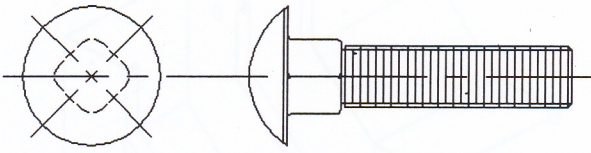

CARRIAGE BOLT LONG NECK

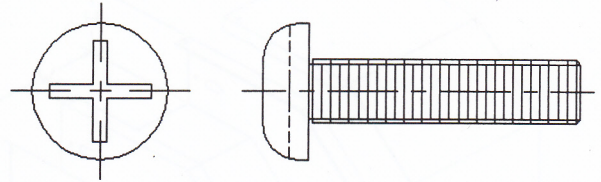

PAN HEAD BOLT

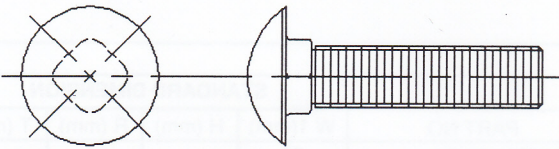

CARRIAGE BOLT SHORT NECK

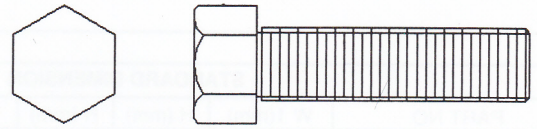

HEX BOLT

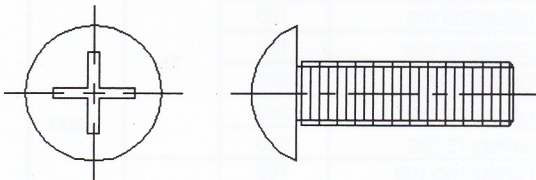

MUSHROOM HEAD BOLT

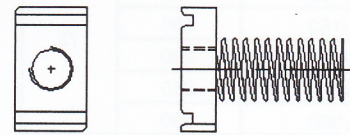

SPRING NUT

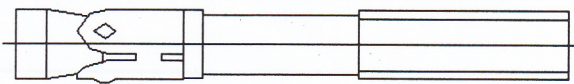

ANCHOR BOLT

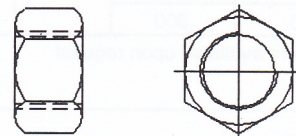

HEX NUT

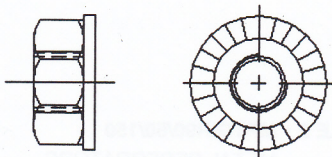

HEX FLANGE NUT

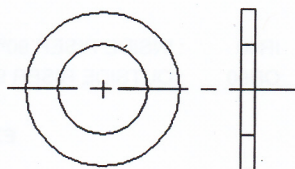

FLAT WASHER

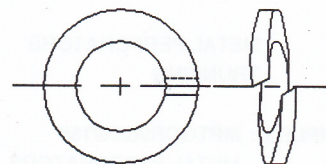

SPRING WASHER